



## HONEYCOMB BLIND COLLECTION

Honeycomb's unique honeycomb shape  
It has a clean design and excellent thermal effect.  
The interior color of the room  
The interior effect is even higher.



HONEYCOMB FABRICS  
COLLECTION

Save Your Heating And Cooling

INVITZ



**We do all production processes  
in Our Factory.**



# PAPER MULBERRY

Honeycomb Fabrics



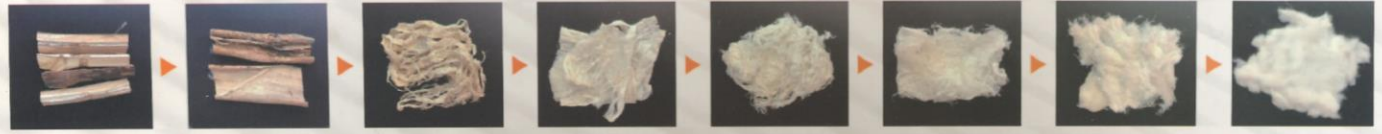

# PAPER MULBERRY FABRICS



## TECHNICAL DATA

**Composition(%)** | Mulberry 10%, Viscose rayon 30%, Polyester 60%  
**Standard Width(m)** | 3.2 **Weight(g/m<sup>2</sup>)** | 171±5% **Thickness(mm)** | 0.35±5%  
**Standard Length(m)** | 24(660cell×2)/Box **Country of Origin** | Made in Korea

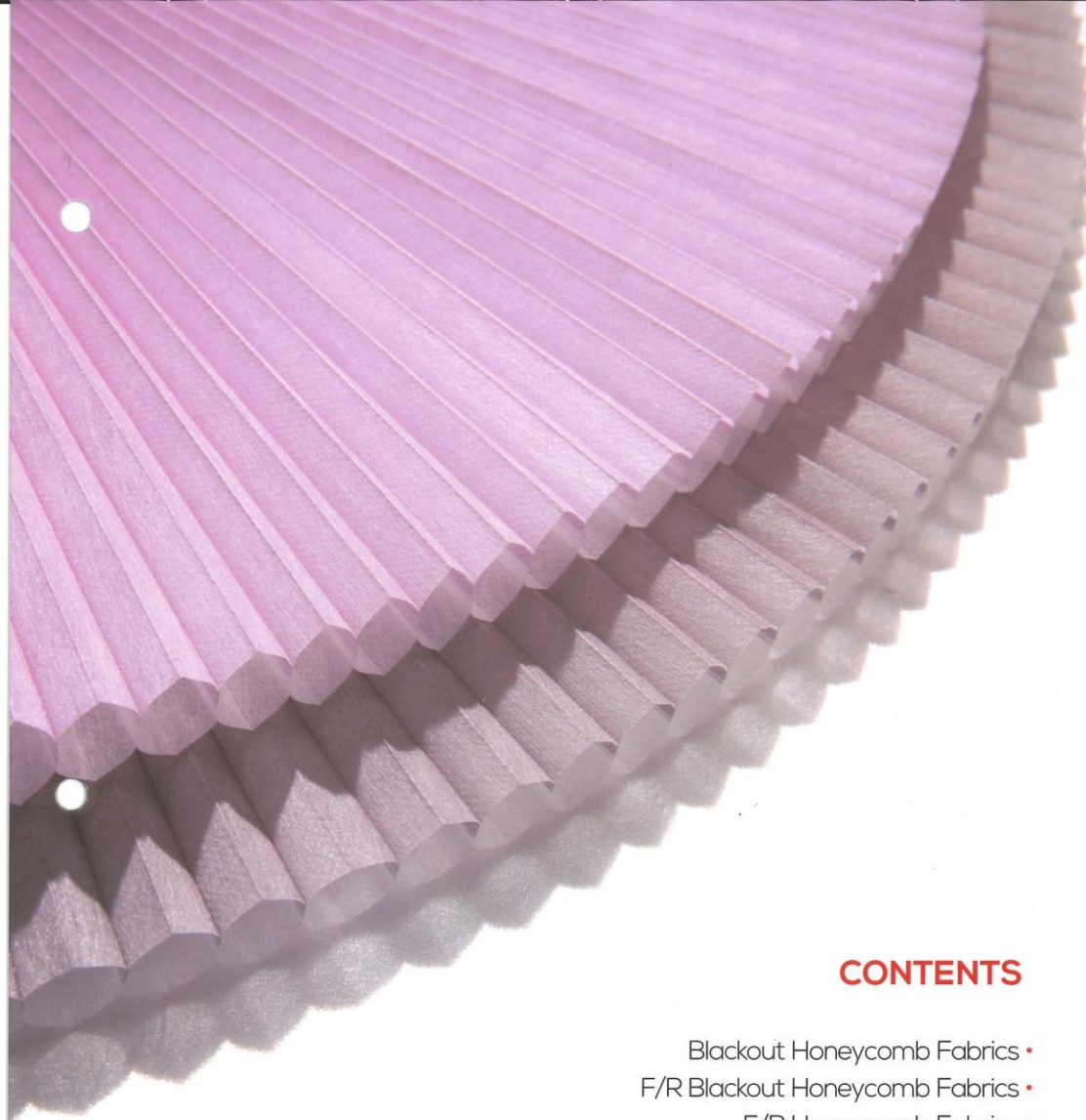

Variety  
of color selection  
for Light Filtering  
and Blackout

## CONTENTS

- Blackout Honeycomb Fabrics •
- F/R Blackout Honeycomb Fabrics •
- F/R Honeycomb Fabrics •
- Sheer Honeycomb Fabrics •
- Sheer 38mm Honeycomb Fabrics •
- Premium Duo Honeycomb Fabrics •
- Full Tone Honeycomb Fabrics •
- Duo Tone Honeycomb Fabrics •
- Premium Duo 38mm Honeycomb Fabrics •





## 허니콤블라인드는

허니콤만의 독특한 벌집모양으로 깨끗한 디자인 연출과 보온효과가 뛰어나며 다양한 색상으로 실내분위기와 인테리어 효과가 한층 더 높아졌습니다. 암막원단은 블라인드중 햇빛 차단율이 뛰어나며, 투톤은 뒤 쪽 원단이 화이트로 되어있어 채광이 되면, 후면이 라이팅 역할을 하기 때문에 전체적으로 은은하고 부드러운 그라데이션 효과가 또한 뛰어납니다.

The cell of the honeycomb structure forms a special air layer, It is a product with high thermal efficiency. (Excellent energy saving effect)

It is a special processed textile product that is durable and wrinkled. It does not occur.

The edge (side line) is not loose because there is no joint.

When the upper and lower bars are thin and the shade is rolled up The volume is so small that you can take advantage of the wide window space.

The cell of the honeycomb structure absorbs the noise by forming a double membrane

Sound absorption effect is excellent.

Antistatic treatment prevents contamination.

Honeycomb shade

It is a honeycomb structure that is soft and smooth due to the transmission of light and the reflection of light.

It creates a mild interior atmosphere.

## Air Pocket Traps Heat

Save Your Heating And Cooling

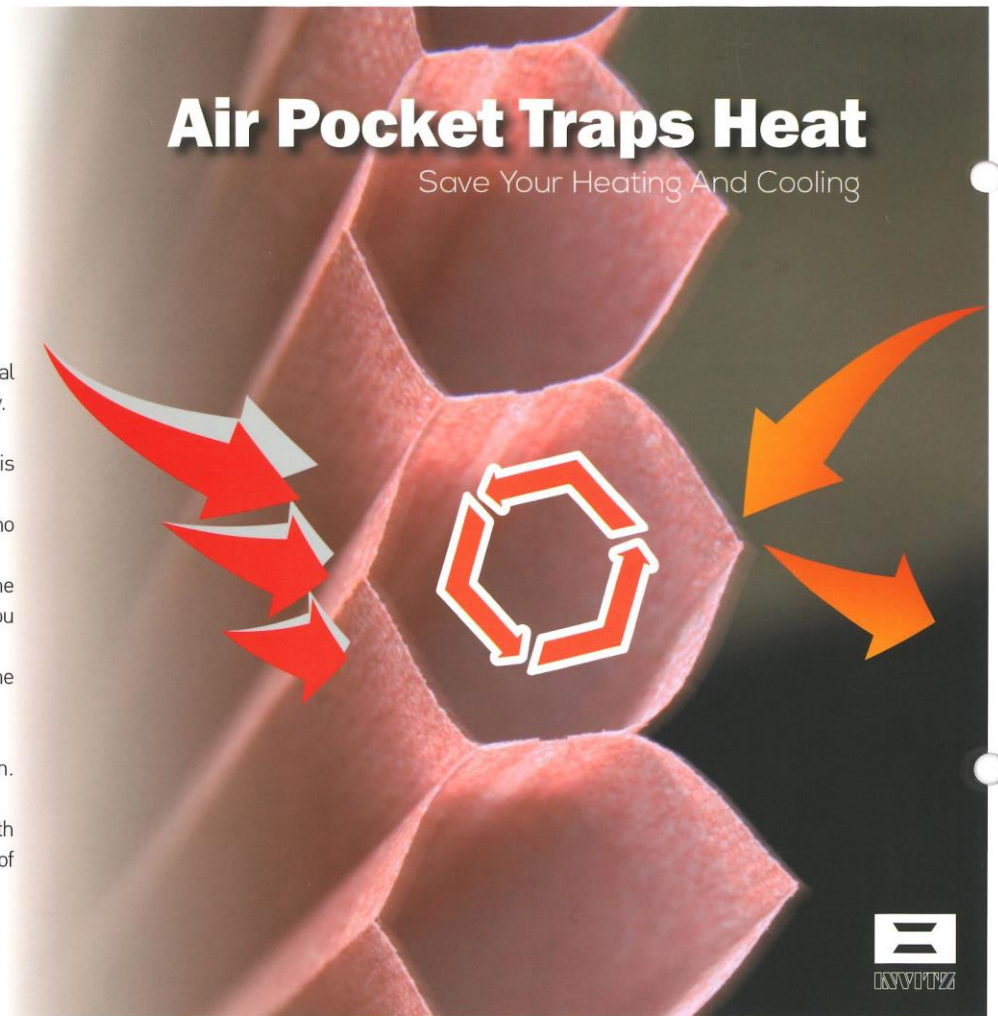





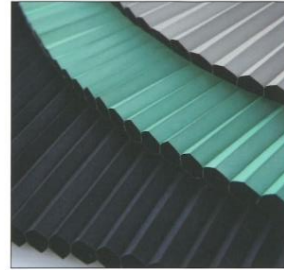



Save Your Heating And Cooling



# BLACKOUT Honeycomb Fabrics



## Blackout Honeycomb Fabrics



### Technical Date

Composition(%) | Polyester Spunbonded 78 ,Aluminum 16 ,Adhesive 6  
 Standard Width(m) | 3.2 Weight(g/m<sup>2</sup>) | 170±5% Thickness(mm/cell) | 0.36±5%  
 Color Fastness | above 4 grade Standard Length(m) | 20 (1100cell) /Box Country of Origin | Made in Korea

## F/R & B/O Honeycomb Fabrics



### Technical Date

Composition(%) | Polyester Spunbonded 78 ,Aluminum 16 ,Adhegive 6  
 Standard Width(m) | 3.2 Weight(g/m<sup>2</sup>) | 170±5% Thickness(mm/cell) | 0.36±5% Fire Classification | KFI



Save Your Heating And Cooling

F/R  
Honeycomb Fabrics



# F/R Honeycomb Fabrics

<i>F.R 25mm</i> FR - 201 WHITE	<i>F.R 25mm</i> FR - 202 IVORY	<i>F.R 25mm</i> FR - 203 FLORAL WHITE
<i>F.R 25mm</i> FR - 204 MOCCASIN	<i>F.R 25mm</i> FR - 205 GAINSBORO	<i>F.R 25mm</i> FR - 206 BARLY WOOD
<i>F.R 25mm</i> FR - 207 LIGHT PURPLE	<i>F.R 25mm</i> FR - 208 INDIGO BLUE	<i>F.R 25mm</i> FR - 209 BLACK
<i>F.R 25mm</i> FR - 210 DARK BLUE	<i>F.R 25mm</i> FR - 211 ICE BLUE	<i>F.R 25mm</i> FR - 212 INDIAN PINK
<i>F.R 25mm</i> FR - 213 STONE RED	<i>F.R 25mm</i> FR - 214 WINE	<i>F.R 25mm</i> FR - 215 WATER GREEN

## Technical Date

Composition(%) | Polyester Spunbonded 94 ,  
Adhesive 6

Standard Width(m) | 3.2

Weight(g/m<sup>2</sup>) | 170±5%

Thickness(mm/cell) | 0.36±5%

Fire Classification | KFI

Color Fastness | above 4 grade

Standard Length(m) | 20 (1100cell) /Box

Country of Origin | Made in Korea





Save Your Heating And Cooling

**SHEER**  
Honeycomb Fabrics

## Sheer Honeycomb Fabrics

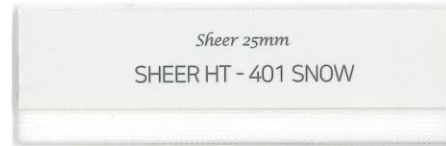

### Technical Date

Composition(%) | Polyester 98 Adhesive 2

Standard Width(m) | 3.0 Weight(g/m<sup>2</sup>) | 128±5% Thickness(mm/cell) | 0.33±5%

Color Fastness | above 4 grade Standard Length(m) | 20 (1100cell) /Box Country of Origin | Made in Korea

## Sheer 38mm Honeycomb Fabrics

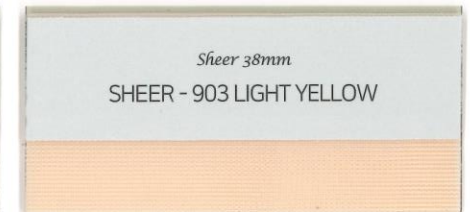
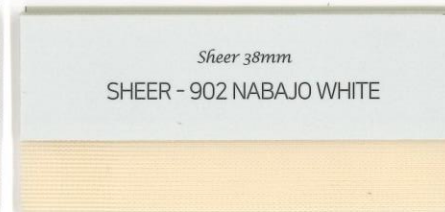

### Technical Date

Composition(%) | Polyester 97 Adhesive 3

Standard Width(m) | 3.0 Weight(g/m<sup>2</sup>) | 104±5% Thickness(mm/cell) | 0.33±5%

Color Fastness | above 4 grade Standard Length(m) | 20 (660cell) /Box Country of Origin | Made in Korea









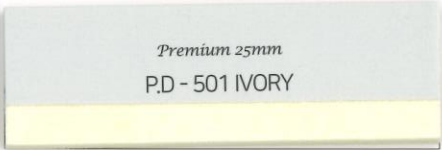
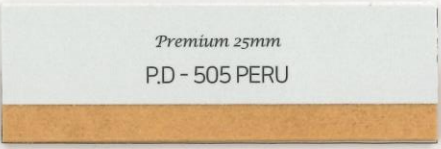

Save Your Heating And Cooling

# PREMIUM DUO

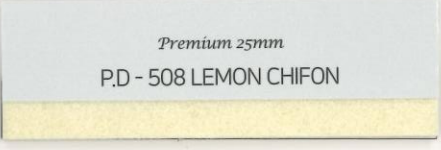
Honeycomb  
Fabrics

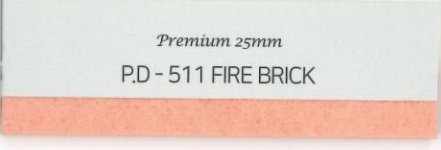

# Premium Duo Honeycomb Fabrics

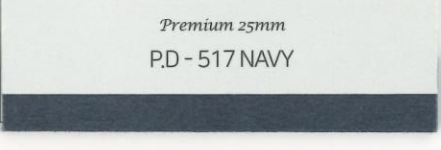
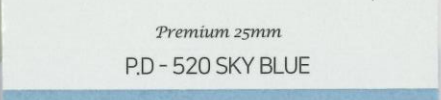
<p><i>Premium 25mm</i> P.D - 501 IVORY</p> 	<p><i>Premium 25mm</i> P.D - 502 PAPAYA WHIP</p> 	<p><i>Premium 25mm</i> P.D - 503 BEIGE</p> 
<p><i>Premium 25mm</i> P.D - 504 BARLY WOOD</p> 	<p><i>Premium 25mm</i> P.D - 505 PERU</p> 	<p><i>Premium 25mm</i> P.D - 506 DARK RED</p> 
<p><i>Premium 25mm</i> P.D - 507 MAROON</p> 	<p><i>Premium 25mm</i> P.D - 508 LEMON CHIFON</p> 	<p><i>Premium 25mm</i> P.D - 509 LIGHT BLUE</p> 
<p><i>Premium 25mm</i> P.D - 510 CADET BLUE</p> 	<p><i>Premium 25mm</i> P.D - 511 FIRE BRICK</p> 	<p><i>Premium 25mm</i> P.D - 512 SADDLE BROWN</p> 
<p><i>Premium 25mm</i> P.D - 513 RED</p> 	<p><i>Premium 25mm</i> P.D - 514 LIGHT GREY</p> 	<p><i>Premium 25mm</i> P.D - 515 MID BLUE</p> 
<p><i>Premium 25mm</i> P.D - 516 STEEL BLUE</p> 	<p><i>Premium 25mm</i> P.D - 517 NAVY</p> 	<p><i>Premium 25mm</i> P.D - 518 BISQUE</p> 
<p><i>Premium 25mm</i> P.D - 519 SIENNA</p> 	<p><i>Premium 25mm</i> P.D - 520 SKY BLUE</p> 	

**Technical Data**  
 Composition(%) | Polyester 94 Adhesive 6  
 Weight(g/m<sup>2</sup>) | 158±5%  
 Thickness(mm/cell) | 0.33±5%  
 Color Fastness | above 4 grade  
 Standard Length (m) | 20 (1100 - 1100)





**SB-FULL TONE**  
Honeycomb Fabrics

Save Your Heating And Cooling

# SB-Full tone Honeycomb Fabrics

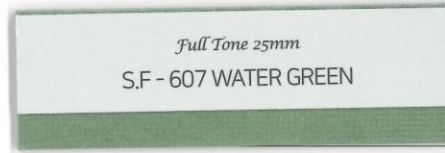
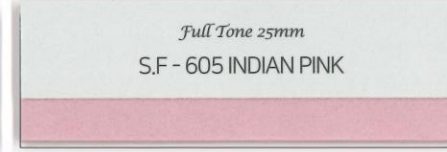
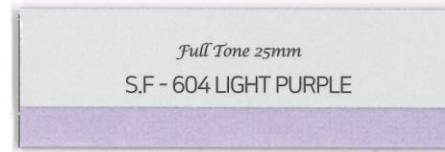
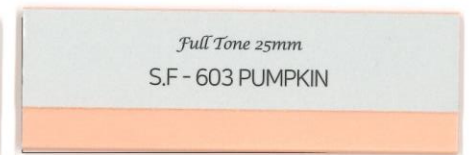
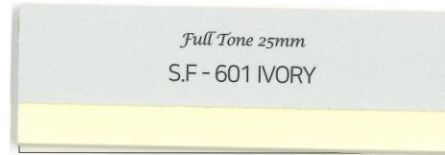

## Technical Date

Composition(%) | Polyester 94.8  
Adhesive 5.2

Standard Width(m) | 3.2

Weight(g/m<sup>2</sup>) | 134±5%

Thickness(mm/cell) | 0.36±5%

Color Fastness | above 4 grade

Standard Length(m) | 20 (1100cell) /Box

Country of Origin | Made in Korea





Save Your Heating And Cooling

SB-DUO TONE  
Honeycomb Fabrics

# SB-Duo tone Honeycomb Fabrics

<p><i>Duo Tone 25mm</i> S.D - 701 WHITE</p> 	<p><i>Duo Tone 25mm</i> S.D - 702 IVORY</p> 	<p><i>Duo Tone 25mm</i> S.D - 703 LEMON CHIFON</p> 
<p><i>Duo Tone 25mm</i> S.D - 704 CAPPUCCINO</p> 	<p><i>Duo Tone 25mm</i> S.D - 705 BARLY WOOD</p> 	<p><i>Duo Tone 25mm</i> S.D - 706 MILK COCONUT</p> 
<p><i>Duo Tone 25mm</i> S.D - 707 SOFT KAKAO</p> 	<p><i>Duo Tone 25mm</i> S.D - 708 AMERICANO</p> 	<p><i>Duo Tone 25mm</i> S.D - 709 STONE RED</p> 
<p><i>Duo Tone 25mm</i> S.D - 710 INDIAN PINK</p> 	<p><i>Duo Tone 25mm</i> S.D - 711 ANTIQUE PINK</p> 	<p><i>Duo Tone 25mm</i> S.D - 712 RASPBERRY PINK</p> 
<p><i>Duo Tone 25mm</i> S.D - 713 WINE</p> 	<p><i>Duo Tone 25mm</i> S.D - 714 PUMPKIN</p> 	<p><i>Duo Tone 25mm</i> S.D - 715 YELLOW</p> 
<p><i>Duo Tone 25mm</i> S.D - 716 MARI GOLD</p> 	<p><i>Duo Tone 25mm</i> S.D - 717 APRICOT</p> 	<p><i>Duo Tone 25mm</i> S.D - 718 PEACH CORAL</p> 
<p><i>Duo Tone 25mm</i> S.D - 719 COPPER ORANGE</p> 	<p><i>Duo Tone 25mm</i> S.D - 720 COBALT GREEN</p> 	<p><i>Duo Tone 25mm</i> S.D - 721 ANTIQUE GREEN</p> 



Save Your Heating And Cooling

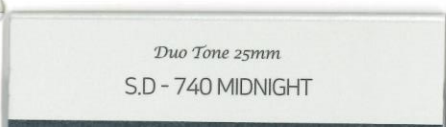
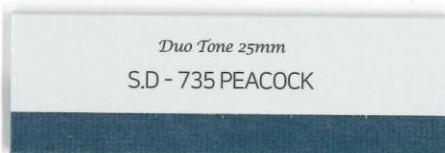
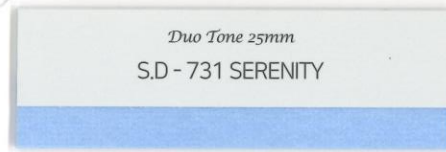
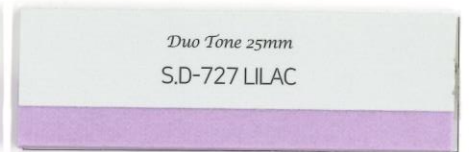

**Technical Date**

Composition(%) | Polyester 94.8 Adhesive 5.2

Standard Width(m) | 3.2 Weight(g/m<sup>2</sup>) | 134±5% Thickness(mm/cell) | 0.36±5%

Color Fastness | above 4 grade. Standard Length(m) | 1.20 (1190±10) Roll Quantity | 60 (5400±100) M

PREMIUM  
DUO 38mm  
Honeycomb Fabrics

Save Your Heating And Cooling

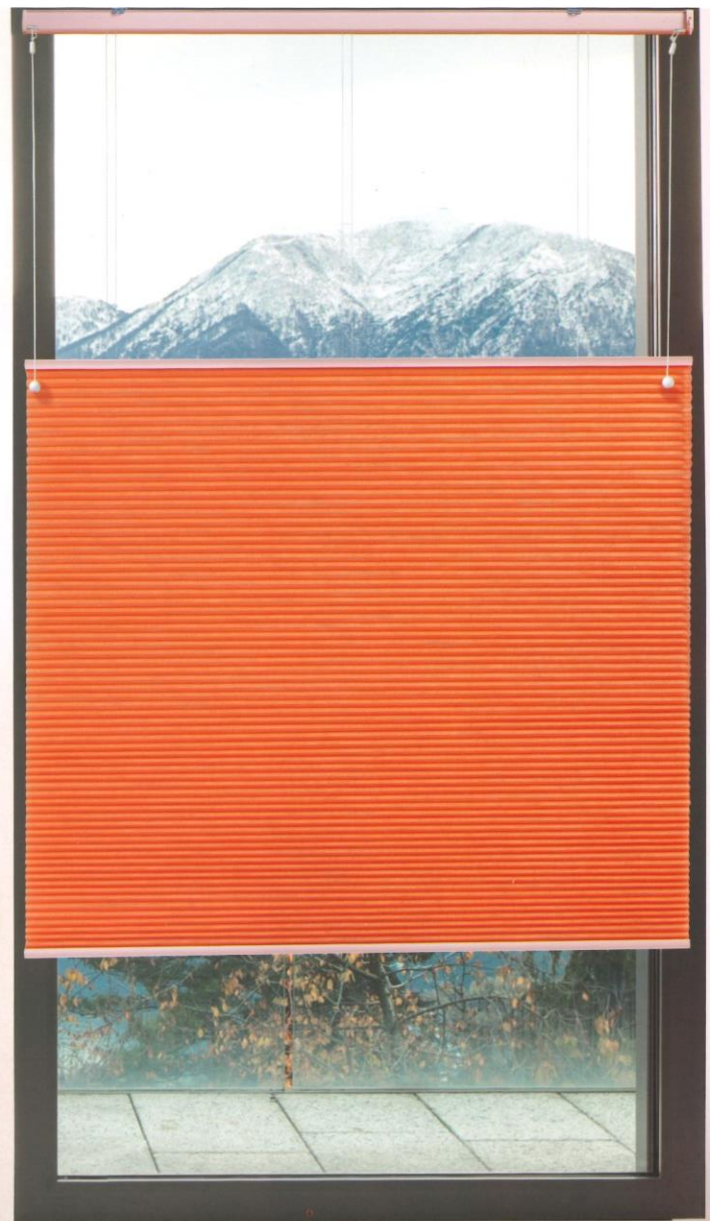



# Premium Duo 38mm Honeycomb Fabrics

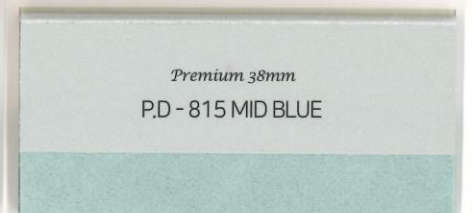
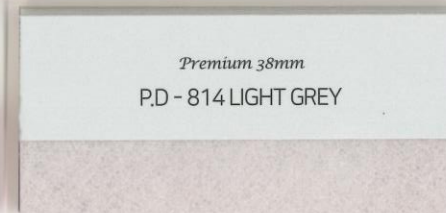
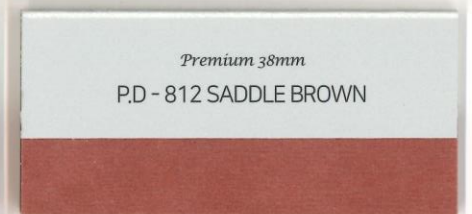
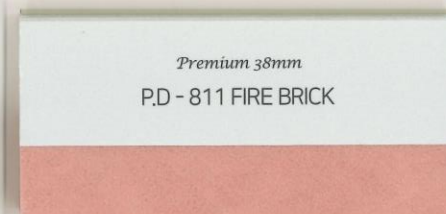
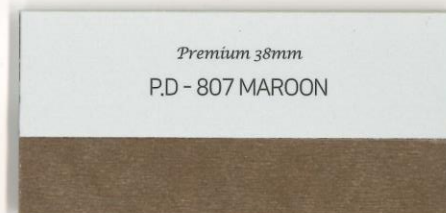
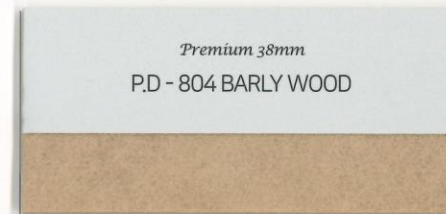
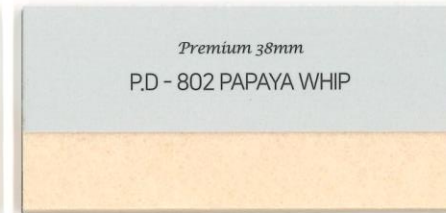
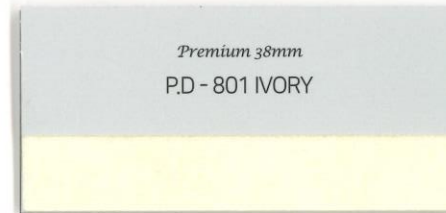

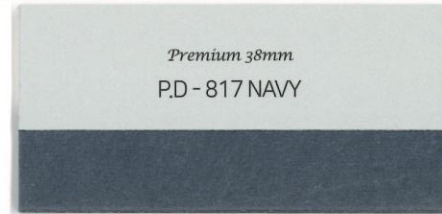

**Technical Data**

Composition(%) | Polyester 94  
Adhesive 6

Standard Width(m) | 3.2

Weight(g/m<sup>2</sup>) | 133±5%

Thickness(mm/cell) | 0.33±5%

Color Fastness | above 4 grade

Standard Length(m) | 20 (660cell)/Box

Country of Origin | Made in Korea





HONEYCOMB FABRICS  
COLLECTION

Save Your Heating And Cooling





## DESIGNING YOUR PERFECT WINDOW SHADINGS

Save Your Heating And Cooling





CUTTING & BORING DEVICE			
Description		Unit	Specification
Device dimension	W x D x H	mm	6620 x 990 x 1080
Cutting size	Length	mm	MAX. 3000
	Width	mm	MAX. 125
Boring size	Diameter	mm	Φ 3.2
	Deep	mm	MAX. 125
Operation mode			Semi-auto
Operation source			Motor & Air cylinder
Motor spec.		kW	0.2
Use air pressure		kg/cm2	4.5-5.5

  

Description		Unit	Specification
Cutting work table	W x D x H	mm	3000 x 600 x 850
Cutting device	W x D x H	mm	600 x 800 x 1080
Boring work table	W x D x H	mm	2420 x 600 x 850
Boring device	W x D x H	mm	600 x 800 x 950

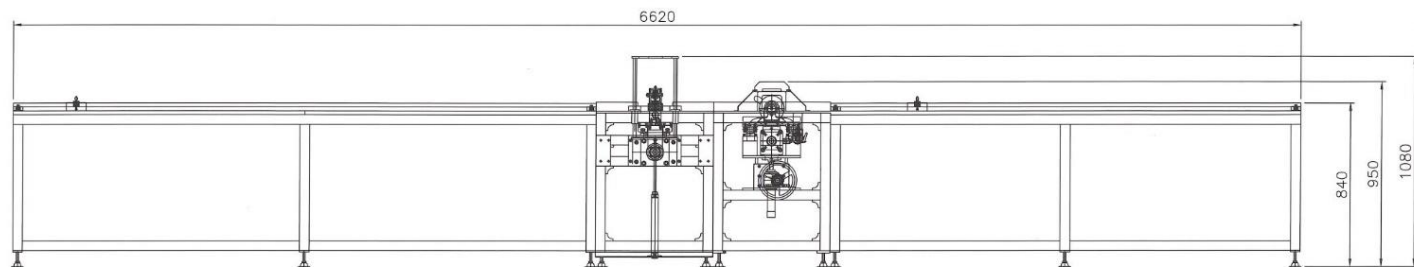
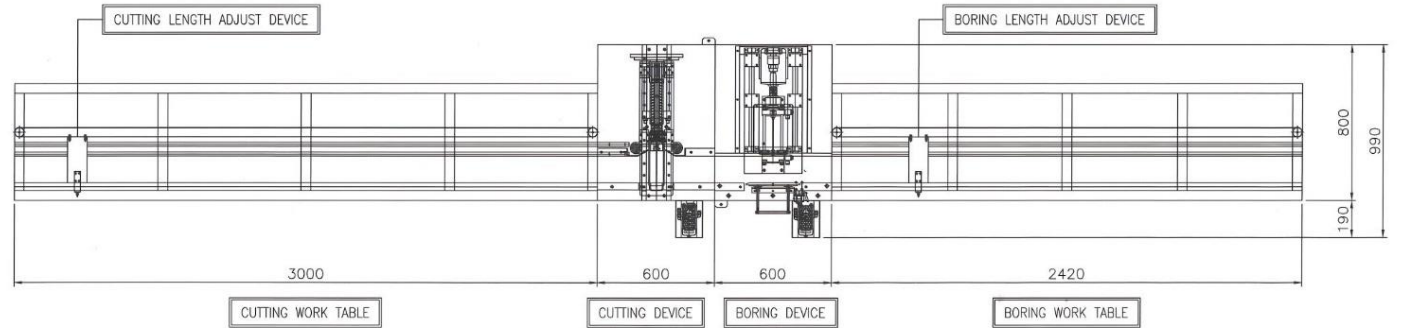



INSPECTION TABLE			
Description		Unit	Specification
Device dimension	W x D x H	mm	5340 x 1066 x 4167
	Length	mm	MIN. 150 ~ MAX. 5000
Inspection size	Width	mm	MIN. 1000 ~ MAX. 3000
	Operation mode		Semi-auto
Operation source		Motor	
Motor spec.		kW	0.75

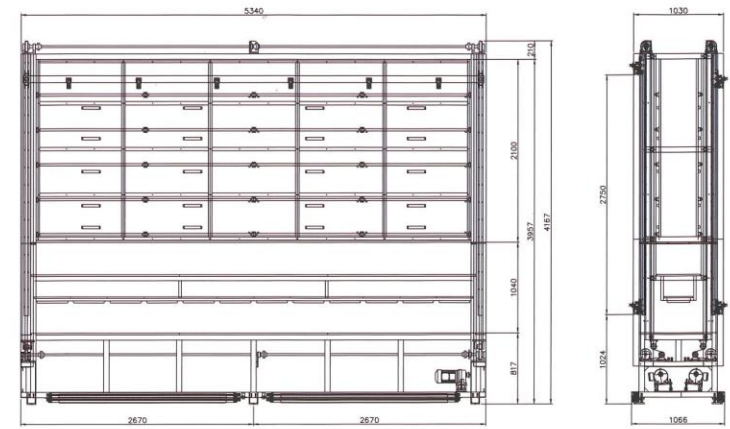

PUNCHING DEVICE			
Description		Unit	Specification
Device dimension	W x D x H	mm	500 x 400 x 1073
	Product size	mm	25, 38, 45
Operation mode		Semi-auto	
Operation source		Air booster & Hyd. cylinder	
Use air pressure		kg/cm2	4.5-5.5

